

REVISIONS				
ECR/DCR	REV.	DESCRIPTION	DATE	APPD
ECR-0421	01	REVISED HOLE DIM'S & BRKT WIDTH PER CUSTOMER REQUEST	4-1-08	EET

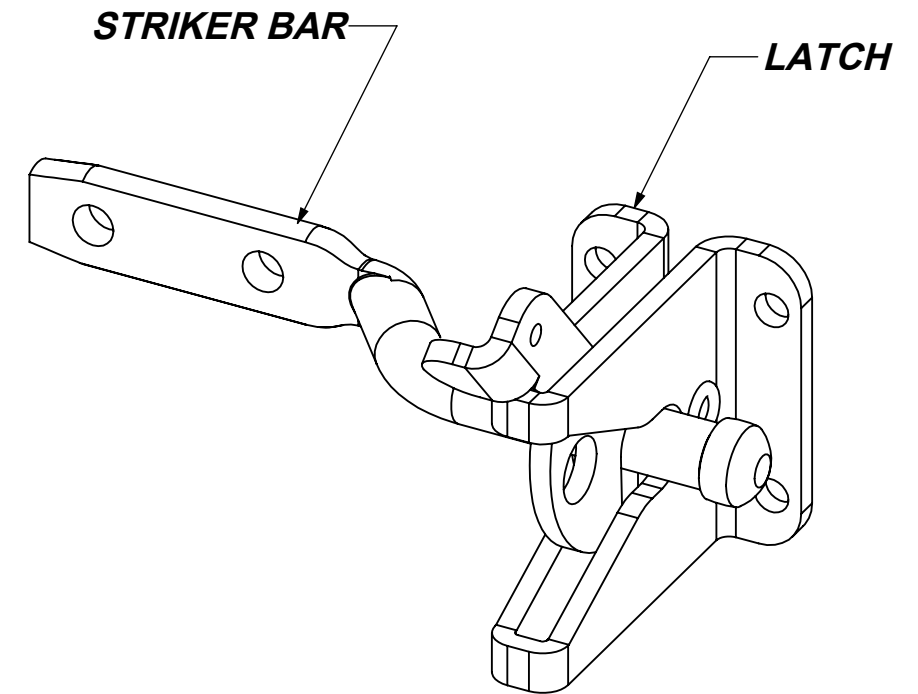
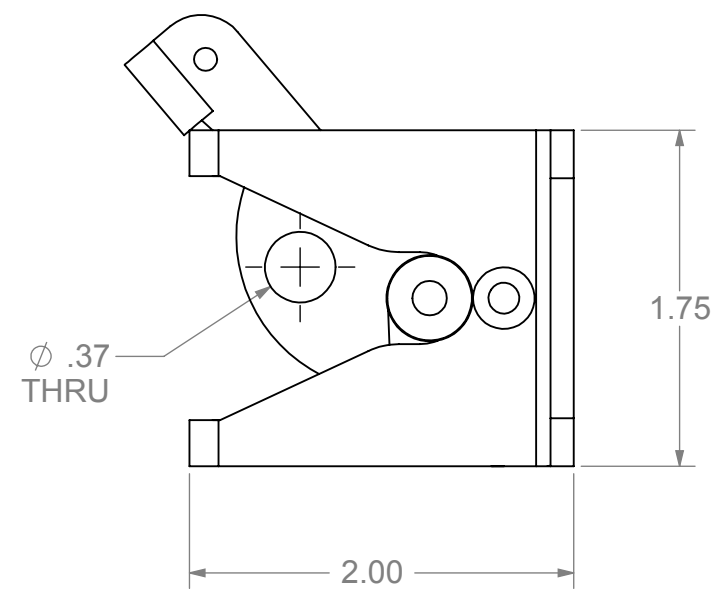
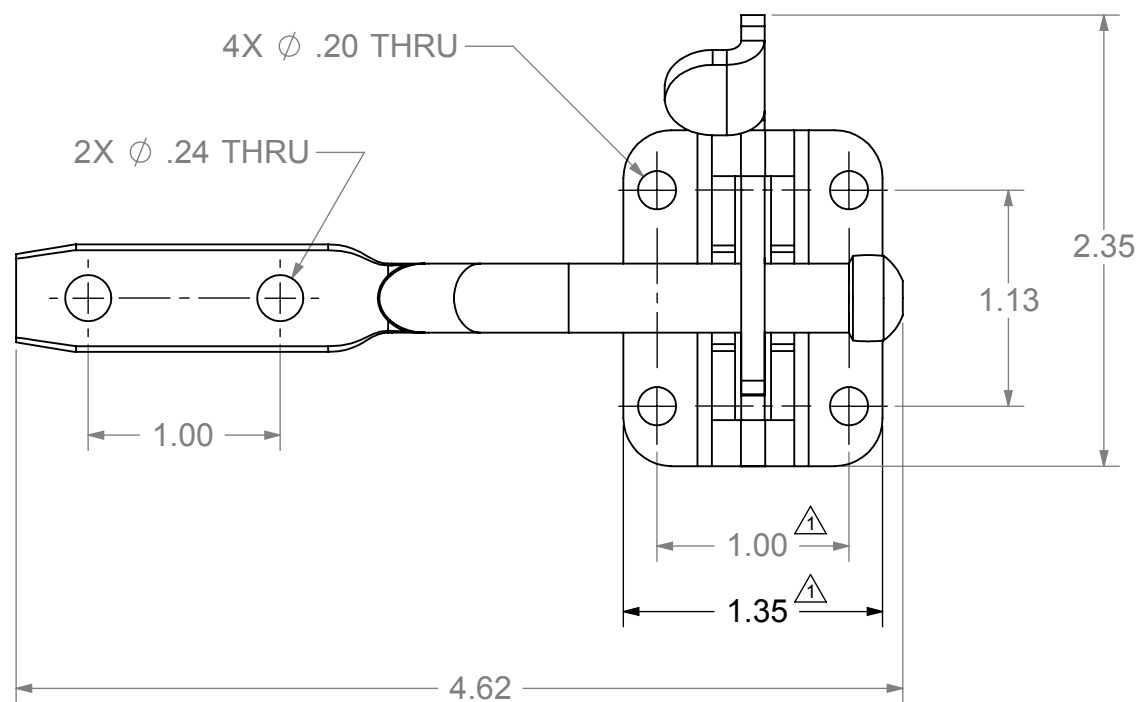
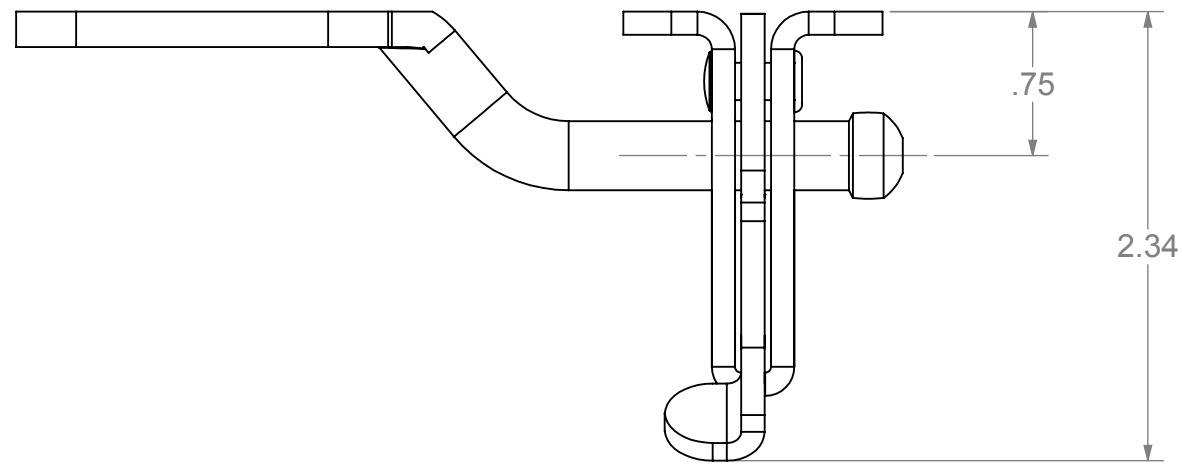

PACKAGING INSTRUCTIONS:

EACH SET MUST BE POLYBAGGED CONTAINING:

1. INDIVIDUALLY POLYBAGGED (1) KEEPER BAR, AND (1) LATCH.
2. POLYBAGGED MOUNTING HARDWARE: (6) #12 x 1" LG. TRUSS HEAD PHILLIPS SCREWS, S/S, BLACK FINISH.

DRAFT COPY

PROPRIETARY AND CONFIDENTIAL

THE INFORMATION CONTAINED IN THIS DRAWING IS THE SOLE PROPERTY OF NATIONWIDE INDUSTRIES. ANY REPRODUCTION IN

NATIONWIDE INDUSTRIES IS PROHIBITED.
DO NOT SCALE DRAWING



GRAVITY LATCH

SIZE	DWG. NO.	REV.
B	CS--NW38204-BSSB	01
SCALE:1:1	WEIGHT: 0.41 LB.	SHEET 1 OF 1