

PART NO.	COLOR
NW38308NUA-SSB	BLACK
NW38308NUA-SSW	WHITE
NW38308NUA-SSRC	RUBBED COPPER

REVISIONS		DATE	APPD
ECR/DCR	REV.	DESCRIPTION	
-	-	INITIAL RELEASE	-
		7-27-10	-

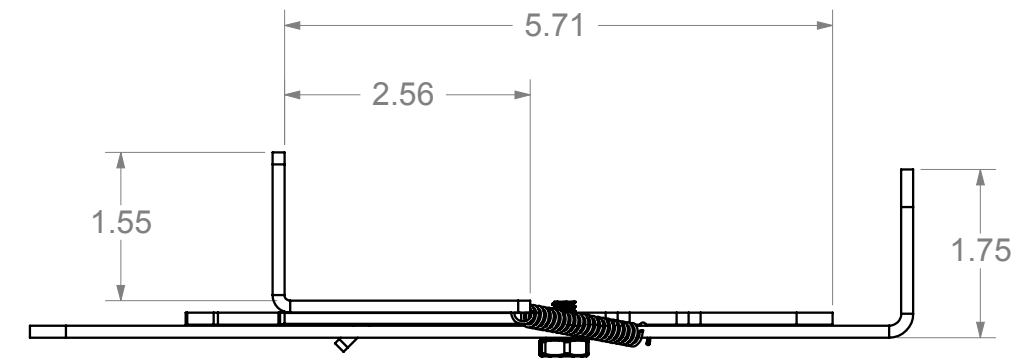
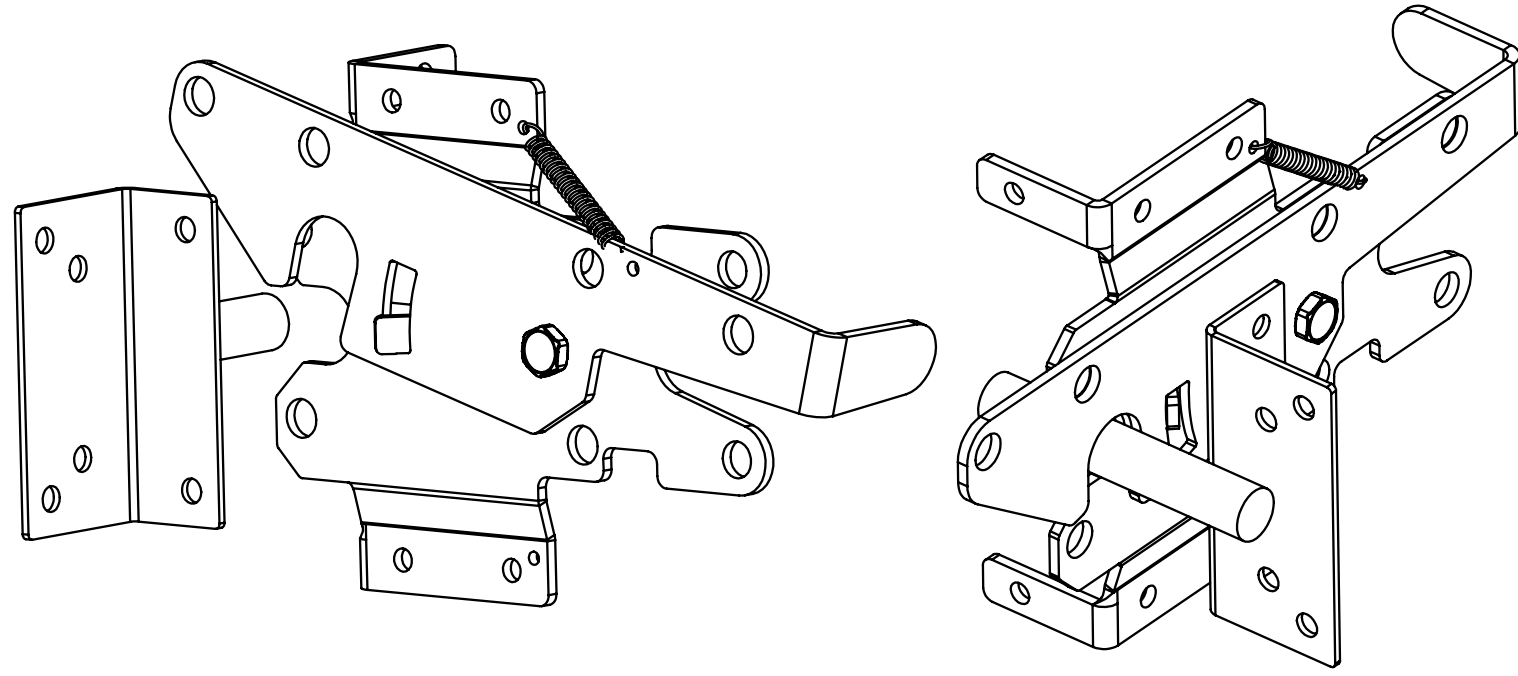

PACKAGING INSTRUCTIONS:

EACH SET TO BE POLYBAGGED AND CONTAIN:

(1) POLYBAGGED SCREW PACK CONTAINING
(12) #14 X 3/4" SS PHILIPS PAN HEAD SHEET
METAL SCREWS

(1) POLYBAGGED LATCH ASSEMBLY

(1) POLYBAGGED STRIKE BAR

20 LATCH SETS PER MASTER CARTON FOR
NW38308NUA-SSB AND NW38308NUA-SSW

12 LATCH SETS PER MASTER CARTON FOR
NW38308NUA-SSRC

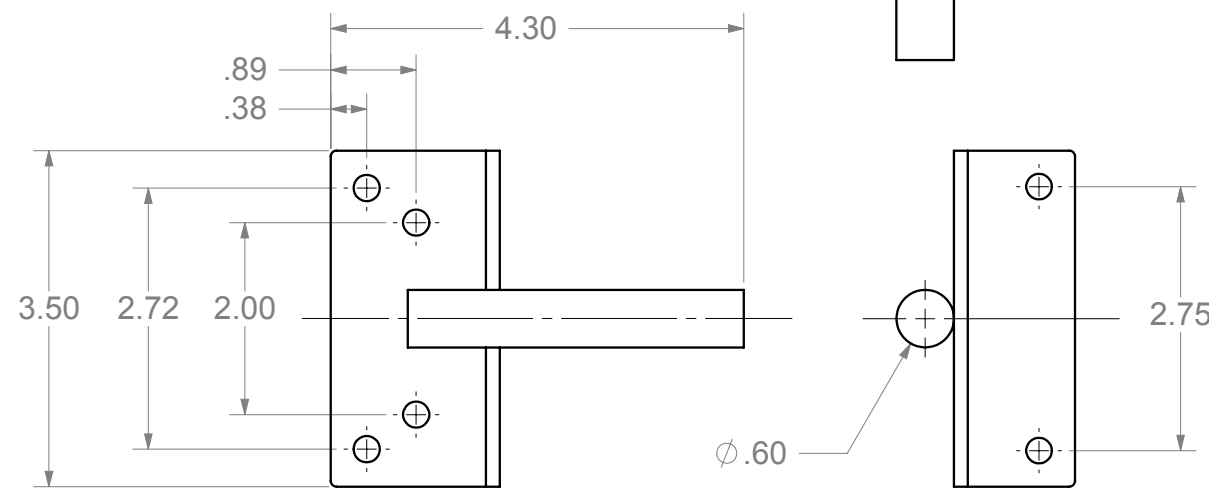
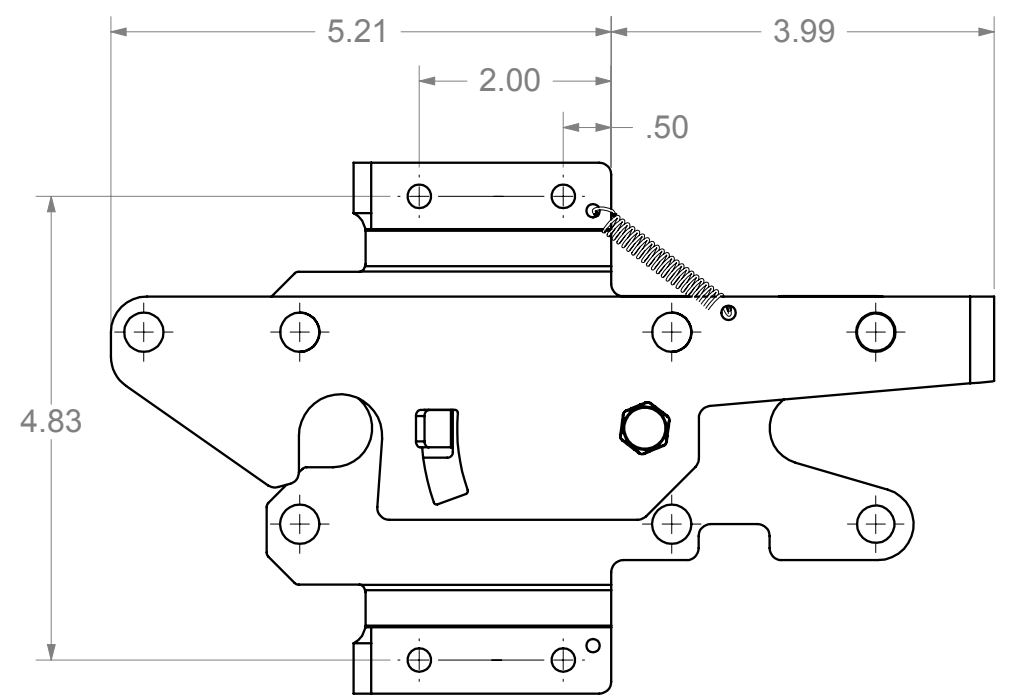
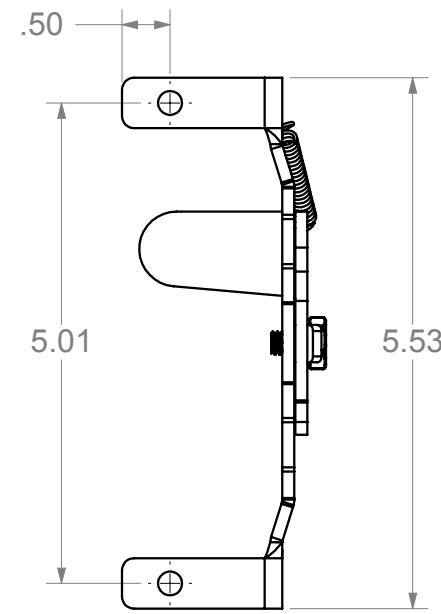
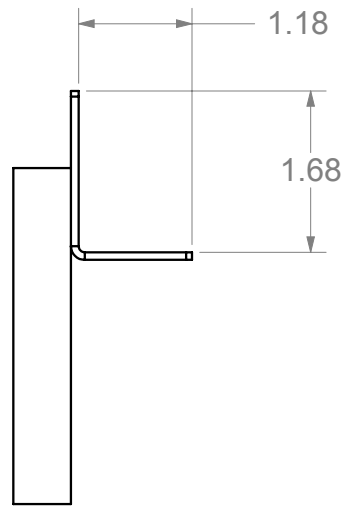

STRIKE BAR

LATCH ASSEMBLY

DRAFT COPY

NOTES:

1. PART TO HAVE A NON-ABRASIVE FINISH.
2. PART TO HAVE MIN. DRAFT ANGLE AS TOOLING REQUIRES.
3. ANY AND ALL CHANGES TO MATERIAL OR FINISH MUST BE APPROVED BY NWI.
4. ALL DIAMETERS TO BE CONCENTRIC WITHIN .005 UNLESS OTHERWISE SPECIFIED.
5. ALL CORNERS TO BE .015 MAX R OR CHAMFER OR OTHERWISE NOTED.
6. ALL DIMENSIONS ARE FINISHED PART DIMENSIONS.

DIMENSIONS ARE IN INCHES
TOLERANCES:
FRACTIONAL ±1/16"
ANGULAR: MACH ±1° BEND ±1°
TWO PLACE DECIMAL ±0.01
THREE PLACE DECIMAL ±0.005

PROPRIETARY AND CONFIDENTIAL
THE INFORMATION CONTAINED IN THIS
DRAWING IS THE SOLE PROPERTY OF
NATIONWIDE INDUSTRIES. ANY
REPRODUCTION IN PART OR AS A WHOLE
WITHOUT THE WRITTEN PERMISSION OF
NATIONWIDE INDUSTRIES IS PROHIBITED.



**POST LATCH
LOCKABLE BOTH SIDES
"ASSEMBLY & DETAILS"**

SIZE	DWG. NO.	REV.
B	CS--NW38308NUA	-
SCALE:1:2	WEIGHT:	SHEET 1 OF 1